

Build Your Own Private 5G Network with Software-Defined Radios

— COM-405 : Mobile Networks —

Instructors: Haitham Al Hassanieh & 5G Team

Laboratory of Sensing and Networking Systems (SENS) @ EPFL

EPFL

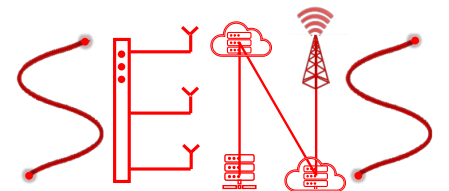

Background

5G Network

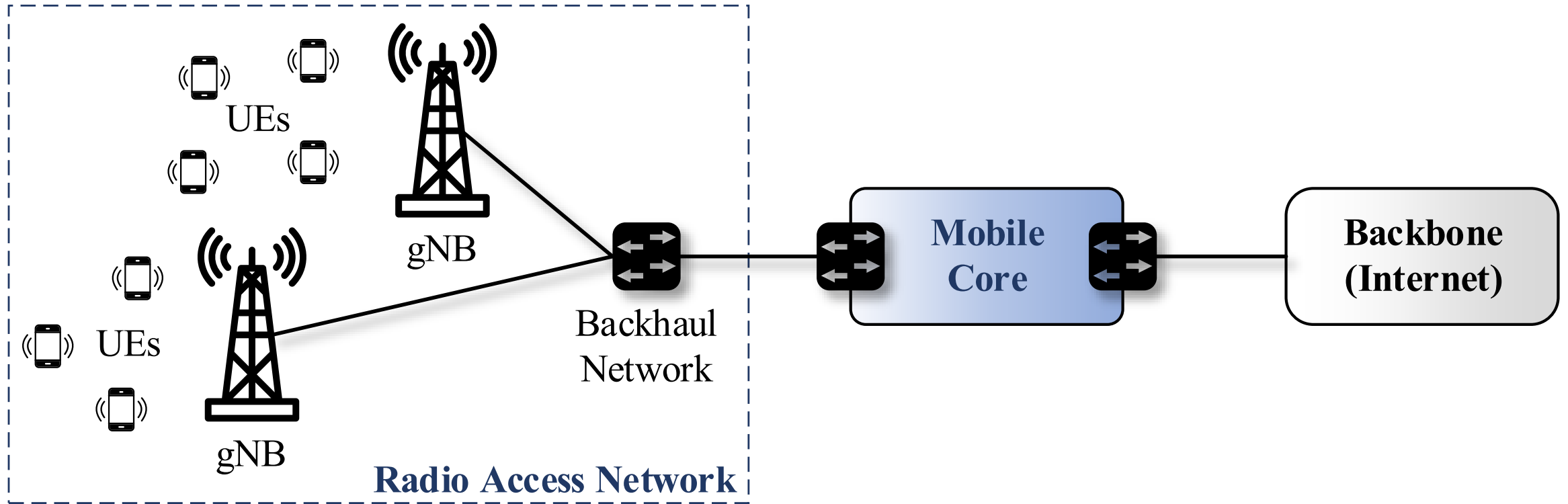

5G Network: **Radio Access Network (RAN)** + **Mobile Core**

- **RAN** : A distributed set of base stations (namely gNB)
- **Mobile Core** : Provide and ensure Internet connectivity

Background

Radio Access Network



Background

Radio Access Network : 5G Protocol Stack

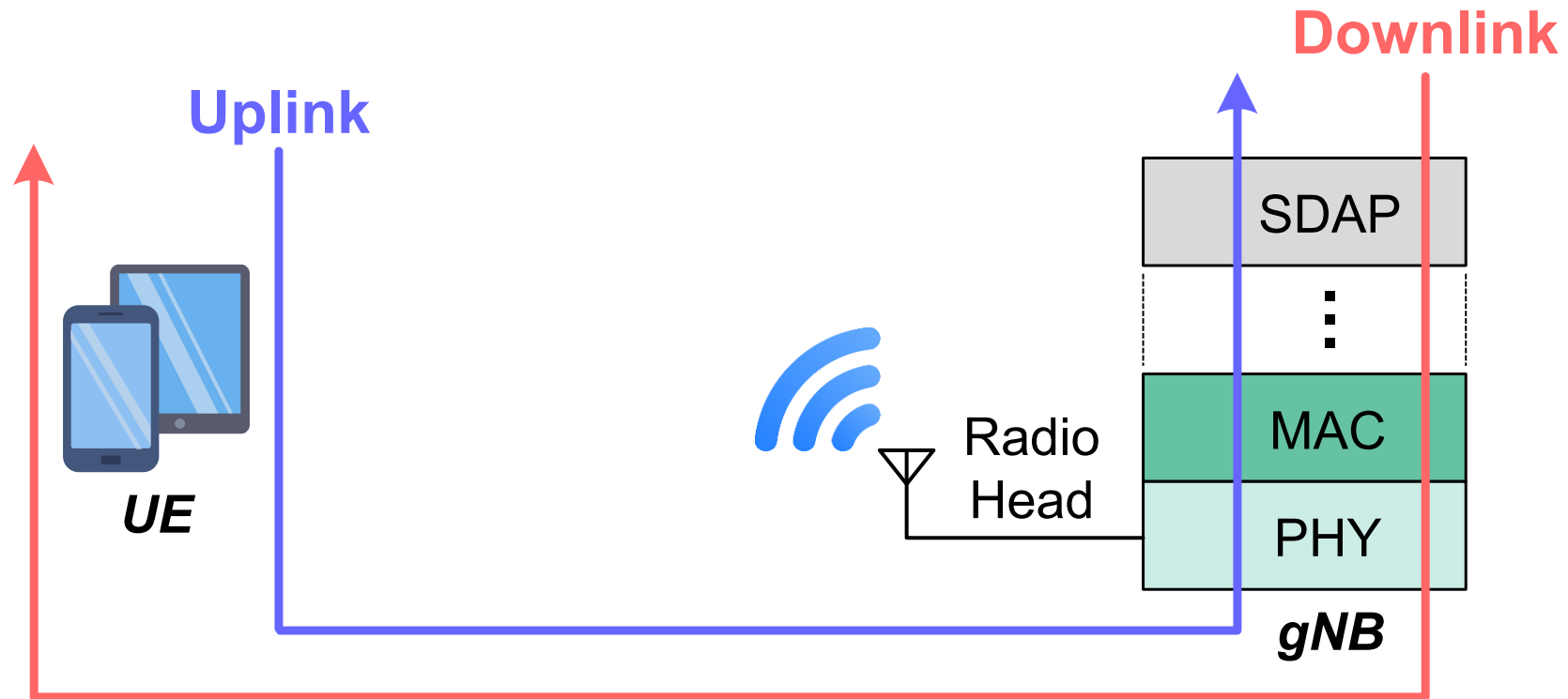

- **Layer 2** : Medium Access Control (MAC)
- **Layer 1** : Physical Layer (PHY) + Radio Head

Background

Mobile Core

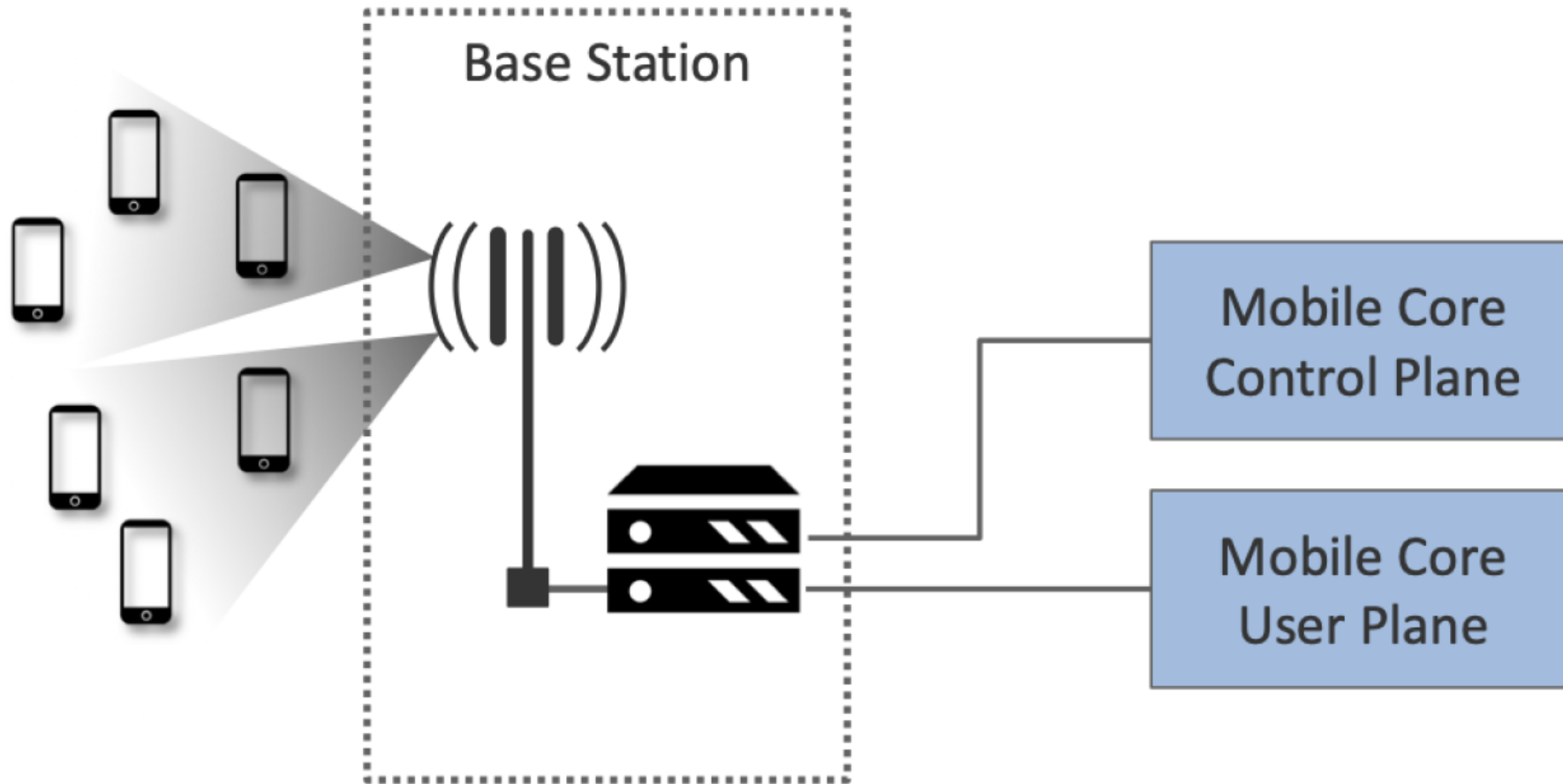

Mobile Core : Control Plane + User Plane

Background

Mobile Core : User Plane

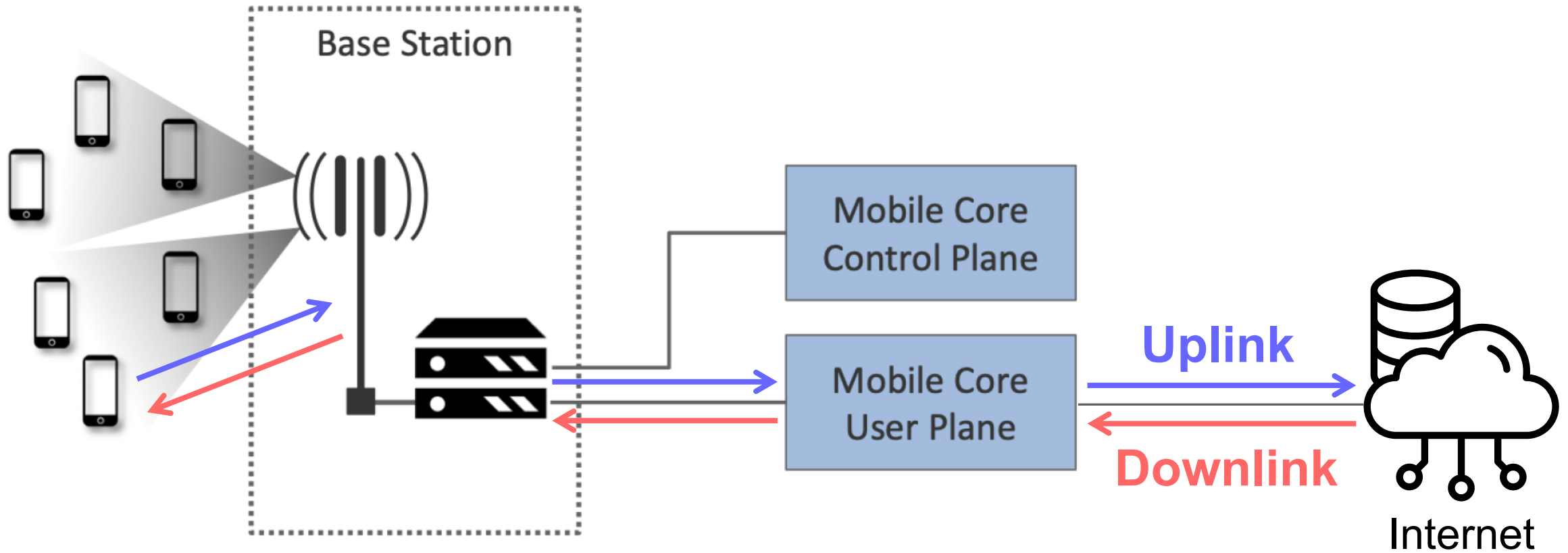

User Plane : Forward data between the RAN and the Internet

Background

Mobile Core : Control Plane

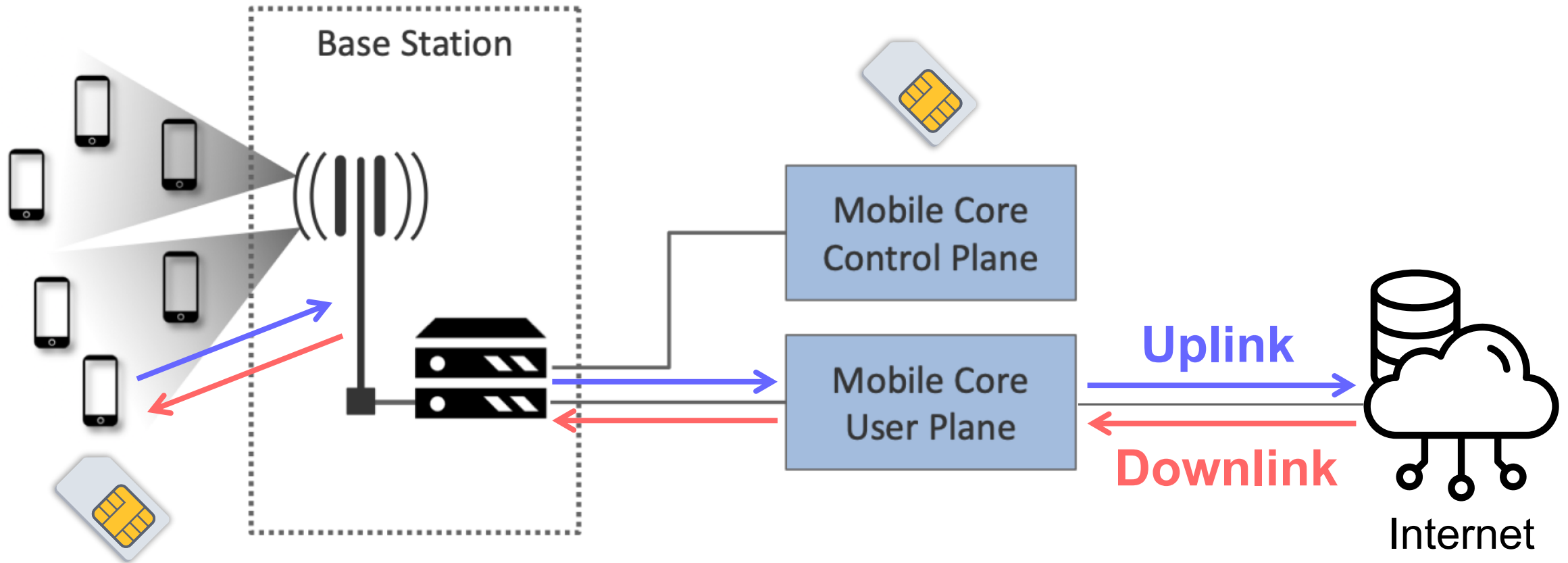

Control Plane : Access authentication, mobility management, location services, etc.

Background

Public 5G Network : Closed Box

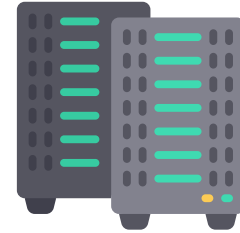
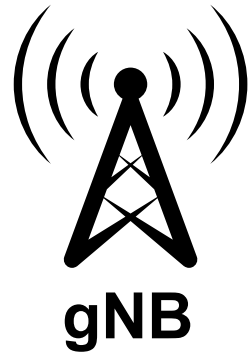

Mobile Core



Single vendor solution

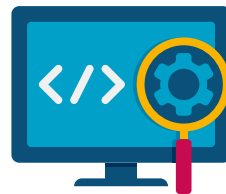

Limit programmability

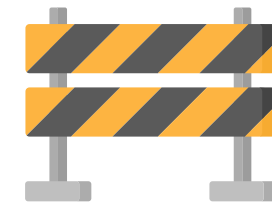

High experimentation barrier

Background

Open-Source 5G Software

Mobile Core :



Radio Access Network :



Full-stack programmability + Ability to experiment on real-world setup

Background

Open-Source 5G Software

Mobile Core :



Radio Access Network :



Full-stack programmability + Ability to experiment on real-world setup

Background

Private 5G Network

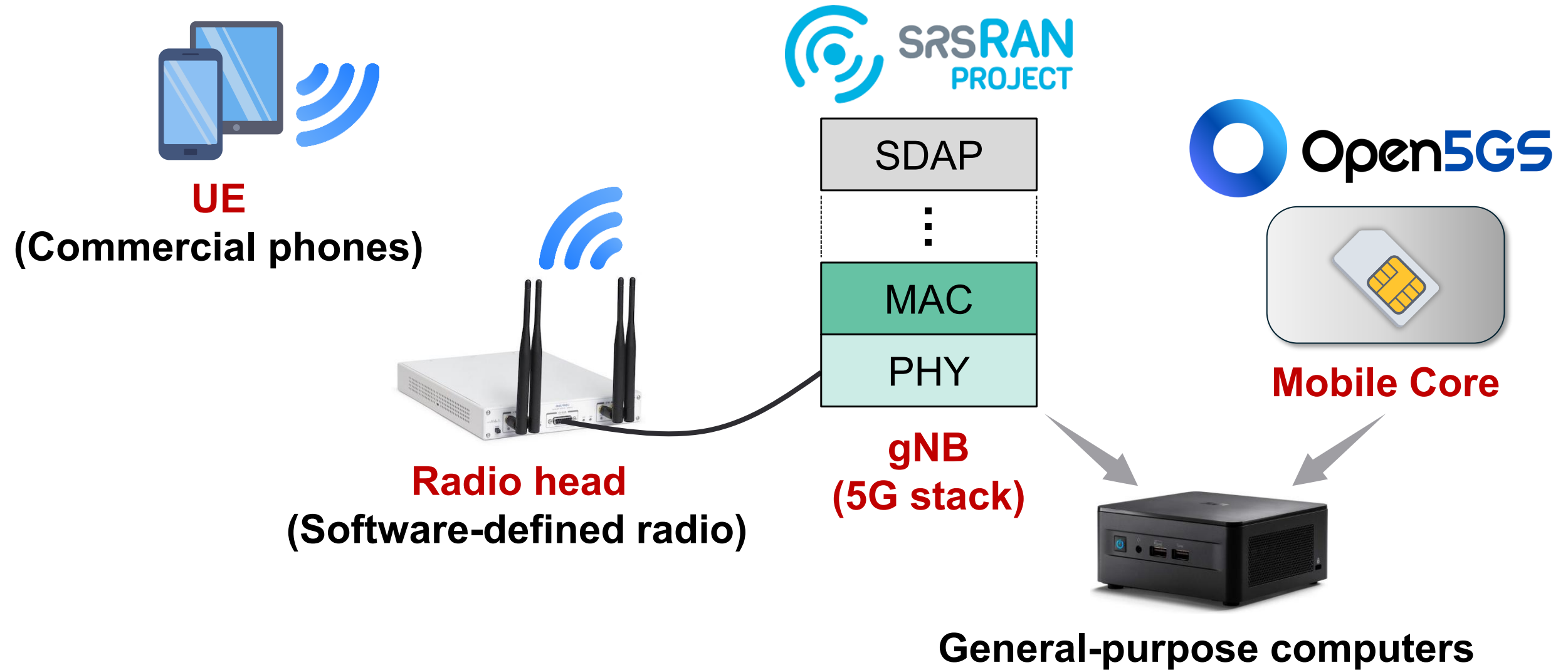

Background

Frequency Band

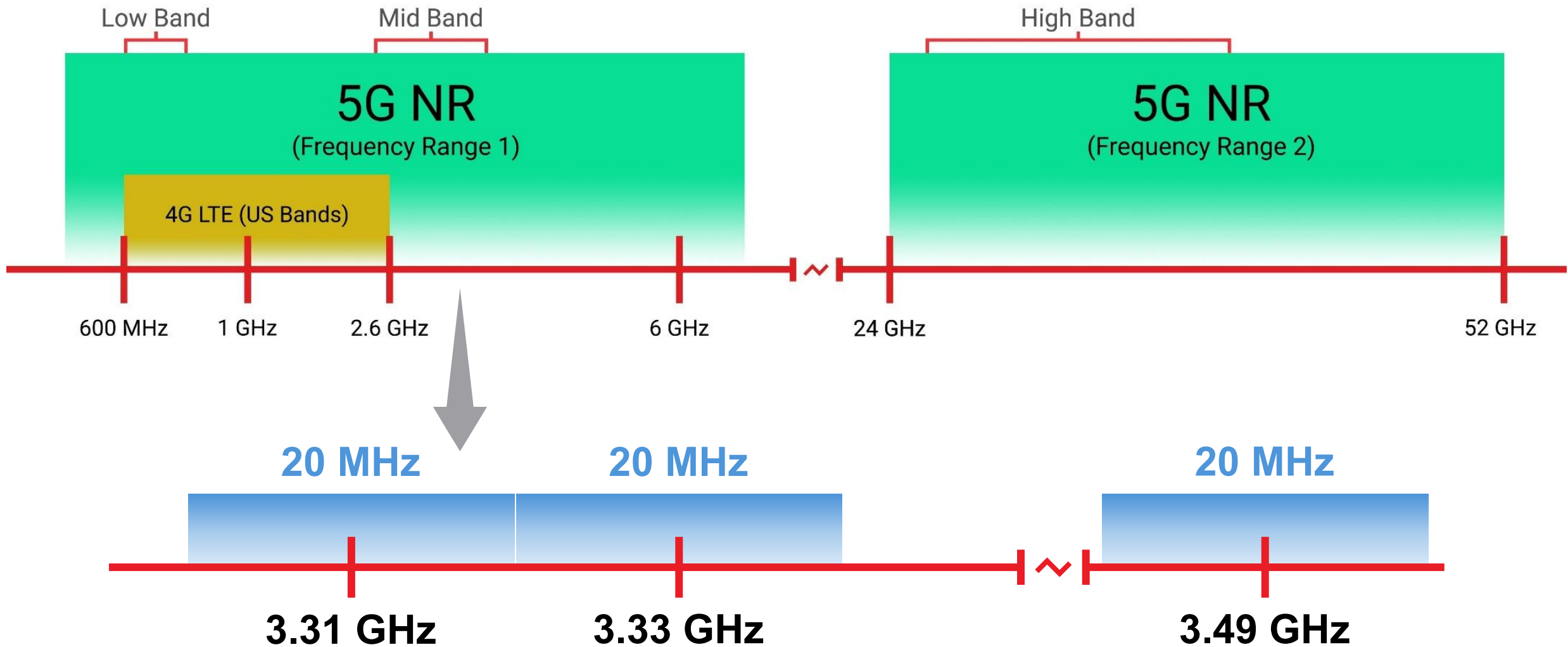

Background

Resource Block

■ Resource block
➤ Smallest unit of resource allocation

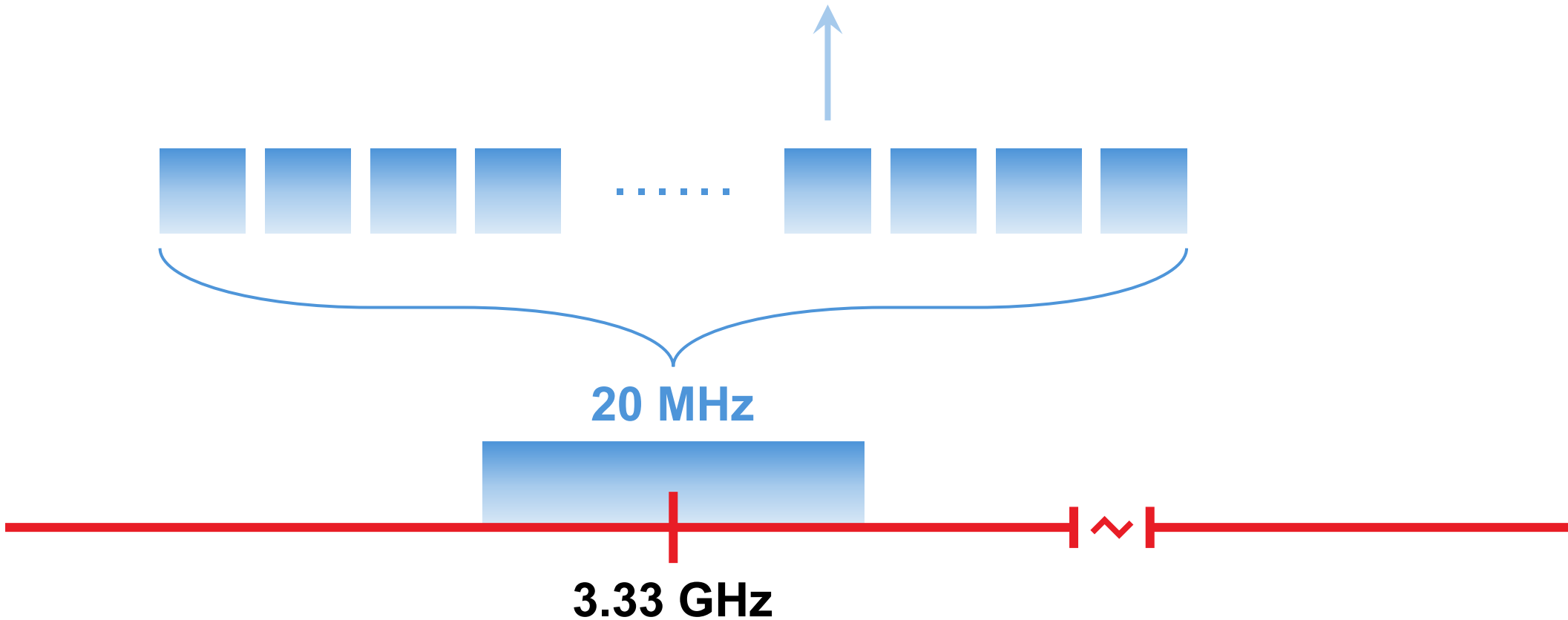

Background

Time Slot

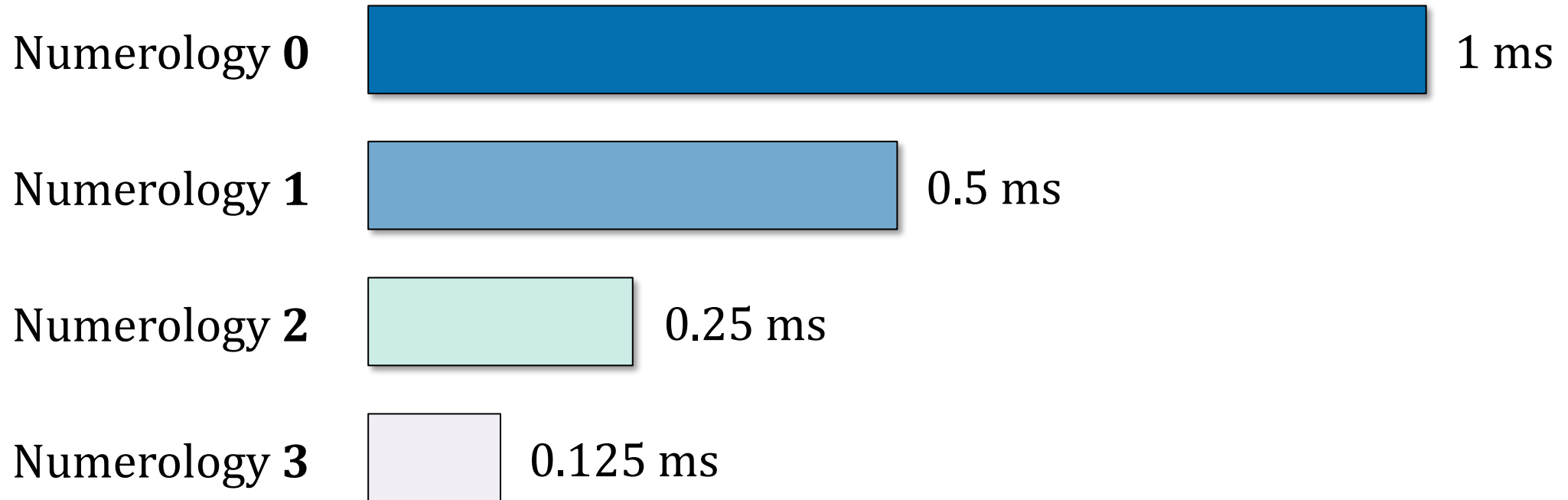

More flexible than 4G → **Numerology** → Slot duration

Background

Time Slot

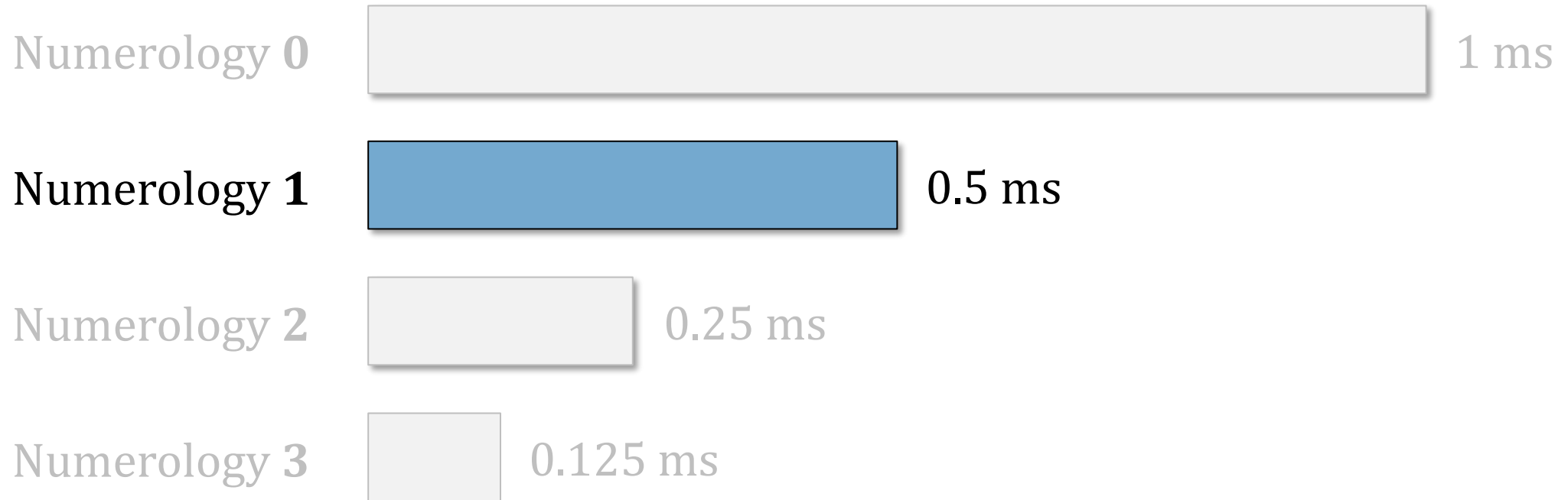

More flexible than 4G → **Numerology** → Slot duration

Background

Physical Resource Allocation

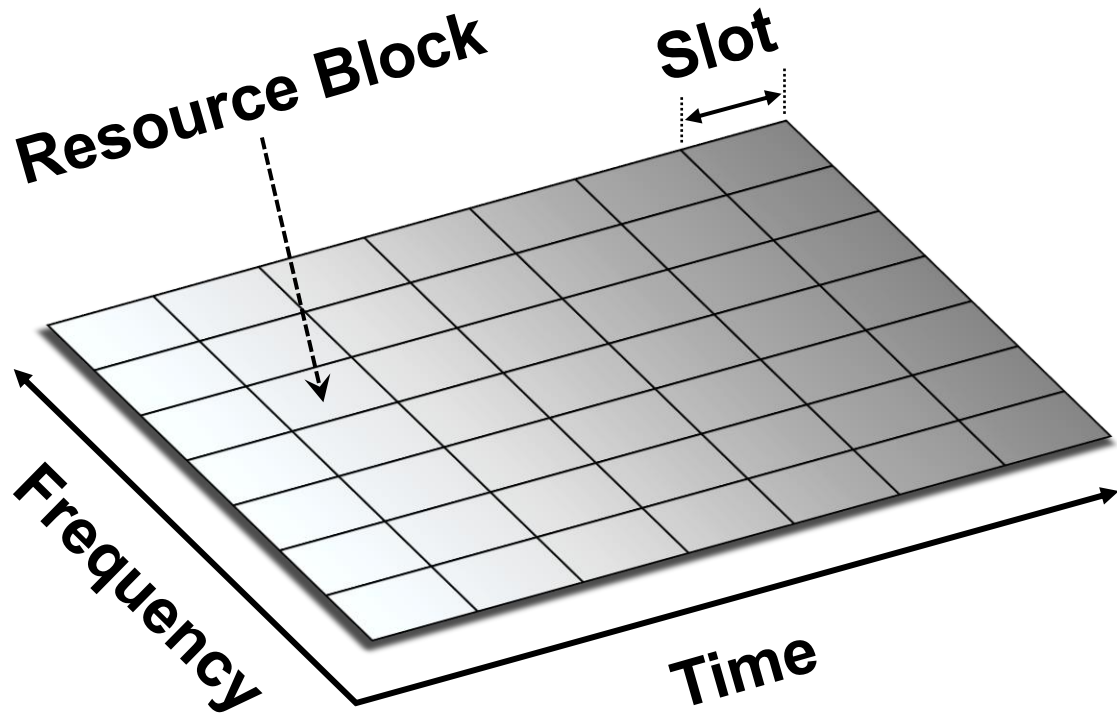

■ Time slot

- 1 ms, 0.5 ms, 0.25 ms, 0.125 ms
- Data is scheduled and transmitted

■ Resource block

- Smallest unit of resource allocation

Background

Duplex Mode : Frequency Division Duplex

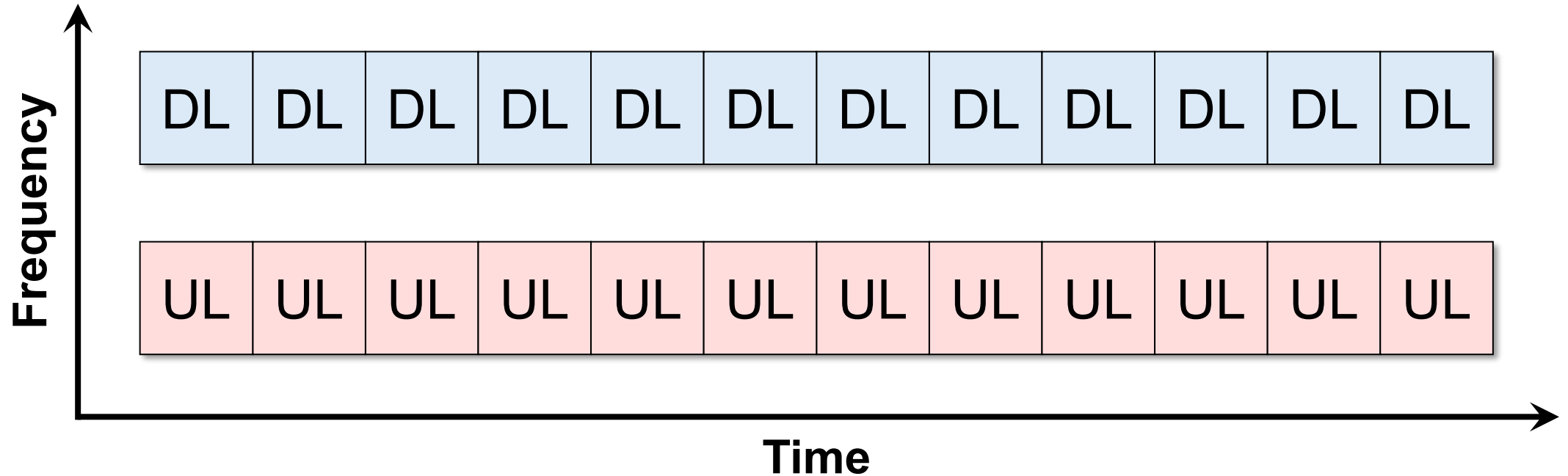

Frequency Division Duplex (FDD)

- Allocate **separate frequency bands** for DL and UL transmissions
- Each slot operates as DL in one frequency band and UL in another

Background

Duplex Mode : Time Division Duplex

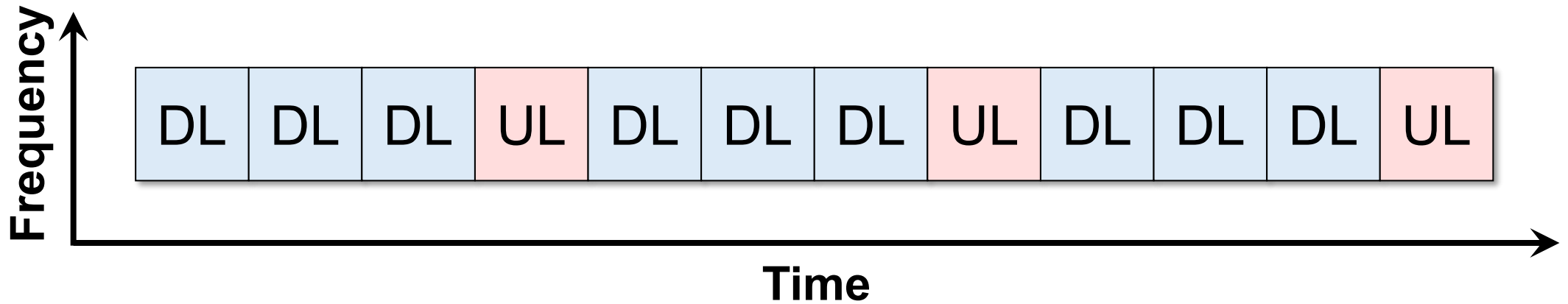

Time Division Duplex (TDD)

- Allocate **the same frequency band** for both DL and UL transmissions
- Each slot explicitly designated as DL or UL

Background

Uplink Scheduling : Grant-Based Access

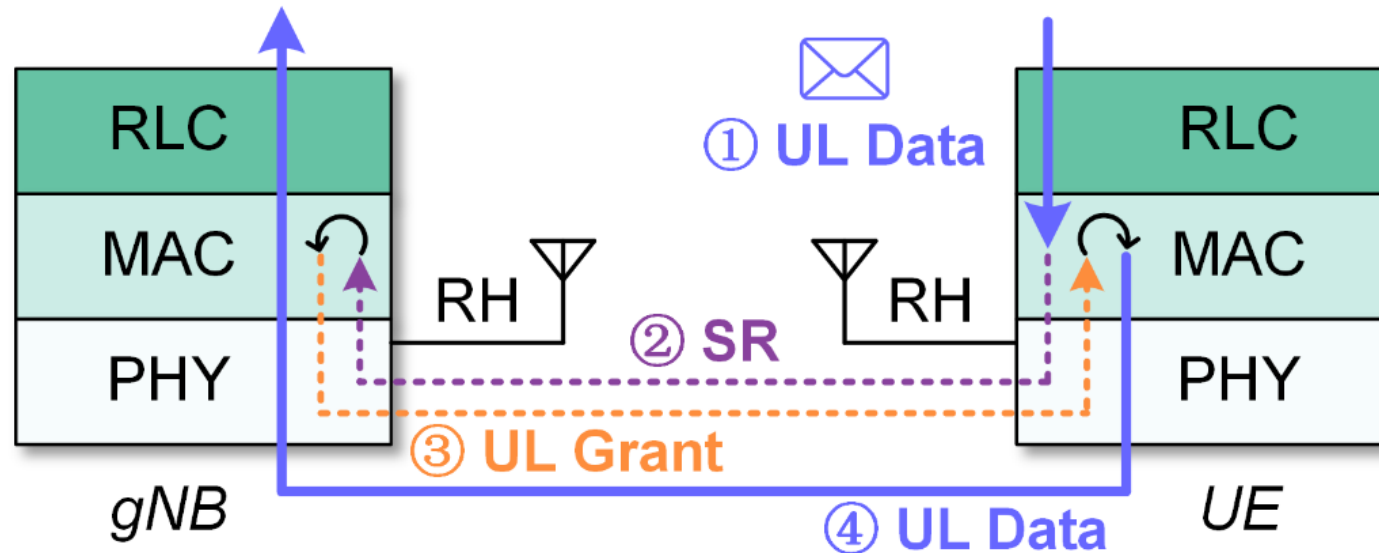

Grant-based access

- A UE first sends a **Scheduling Request (SR)** to the gNB
- The gNB schedules and sends a **grant** to the UE
- The UE transmits **uplink data** to the gNB